

Type	Lr max (mm)	W1 (mm)	M1 (mm)	d1 (mm)	d2 (mm)	h (mm)	F0 (mm)*	F (mm)
HSR15	3000	15	15	4.5	7.5	5.3	35	60
HSR20	4000	20	18	6	9.5	8.5	25	60
HSR25	4000	23	22	7	11	9	25	60
HSR30	4000	28	26	9	14	12	50	80

Type	W (mm)	M (mm)	C (mm)	B (mm)	S (mm)	L (mm)	E (mm)
HSRB15-CA	47	24	30	38	M5	61,6	7
HSRB20-CA	63	30	40	53	M6	78	14
HSRB25-CA	70	36	45	57	M6	85,5	14
HSRB30-CA	90	42	52	72	M8	100,5	14

Type	Ma (kNm)	Ma (kNm)	Mb (kNm)	Mb (kNm)	Mc (kNm)	C (kN)	Co (kN)
Number of blocks	1	2	1	2	-	-	-
HSRB15-CA	0.0805	0.475	0.0805	0.475	0.0844	8.33	13.5
HSRB20-CA	0.19	1.04	0.19	1.04	0.201	13.8	23.8
HSRB25-CA	0.307	1.71	0.307	1.71	0.344	19.9	34.4
HSRB30-CA	0.524	2.7	0.524	2.7	0.562	28	46.8

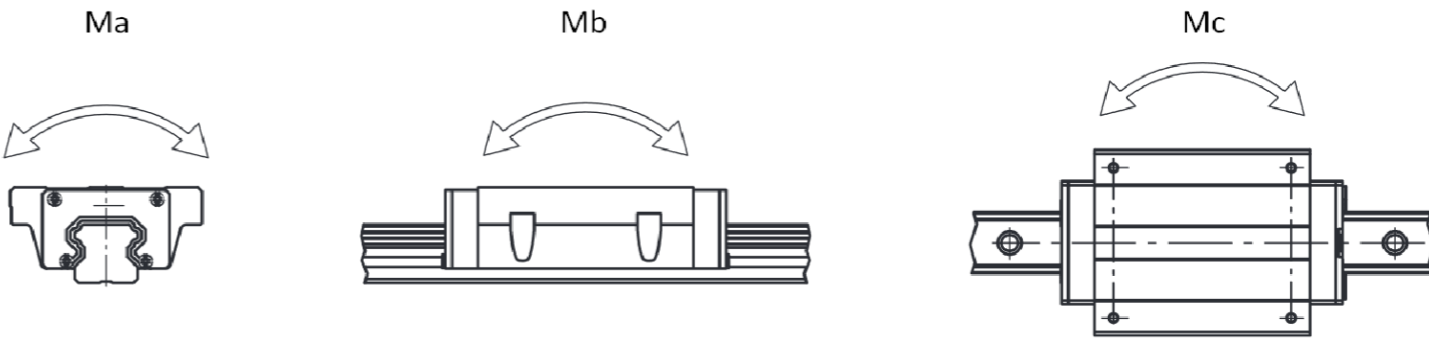

* dimension F0 is marked for factory manufacturing on non cutted rails. Dimension F0 is not guaranteed and need to be specified in order

MATERIAL	STOCK DIM	WEIGHT (g)	SURFACE TREAT.	NOTES

CNC PRISLUSENSTVO. SK This documentation is the intellectual property of CNC PRISLUSENSTVO SK. Feel free to share it and visit our e-shop www.cncprislusenstvo.sk

NAME	SIGN	DATE	Dimensions are in mm Tolerances: ISO 8015 Accuracy: ISO 2768 mK
DRAWN			
CHECKED			
APPROVED			
PRODUCT NAME:			
DWG NAME:			

SCALE	1:2	SIZE	A3
DATE		2/13/2018	
DWG NO.			
HSRCA-Ass			
REVISION :			